

# 规格书

**产品：** LCD 显示屏

**型号：** SX-144V03

客户			上线科技		
批准	审核	检查	批准	审核	拟制

用于承认规格书

用于承认规格书和样品



标准文本	产品规格书	型号	SX-144V03	页数	2
------	-------	----	-----------	----	---

## 目录

1.	概述 -----	3
2.	产品特征 -----	3
3.	机械规格-----	3
4.	外形尺寸 -----	4
5.	接口定义 -----	5
6.	功能框图 -----	6
7.	接口时序 -----	6
8.	复位时序 -----	7
9.	DDRAM 映射表 -----	8
10.	极限技术参数 -----	10
11.	电气参数 -----	10
12.	背光参数 -----	11
13.	光电参数 -----	11
14.	极限环境参数-----	15
15.	可靠性测试 -----	15
16.	LCM 检验标准 -----	16
17.	LCM 的使用-----	19

标准文本	产品规格书	型号	SX-144V03	页数	3
------	-------	----	-----------	----	---

### 1. 概述

#### 1-1 范围:

此份规格书涵盖了 LCM 从上线科技到客户的运输过程中应该注意的所有要求。

#### 1-2 产品:

LCD 模块 (LCM)

#### 1-3 型号:

SX-144V03

### 2. 产品特征

transmissive

(1) 显示类型: Transmissive (全透式), 1.44TFT, COG;

(2) 显示色彩: 65K;

(3) 视角 : 12 点

(4) 点阵 : 128(RGB) (W) ×128H) Pixels;

### 3. 机械规格

项目	规格	单位
外形尺寸	29.50*36.50*2.0	mm
可视区域	25.50*26.50	mm
显示内容	128RGB *128Dots	---
结构类型	COG+FPC+BL	---
背光类型	WHITE LED	—

4. 外形尺寸:

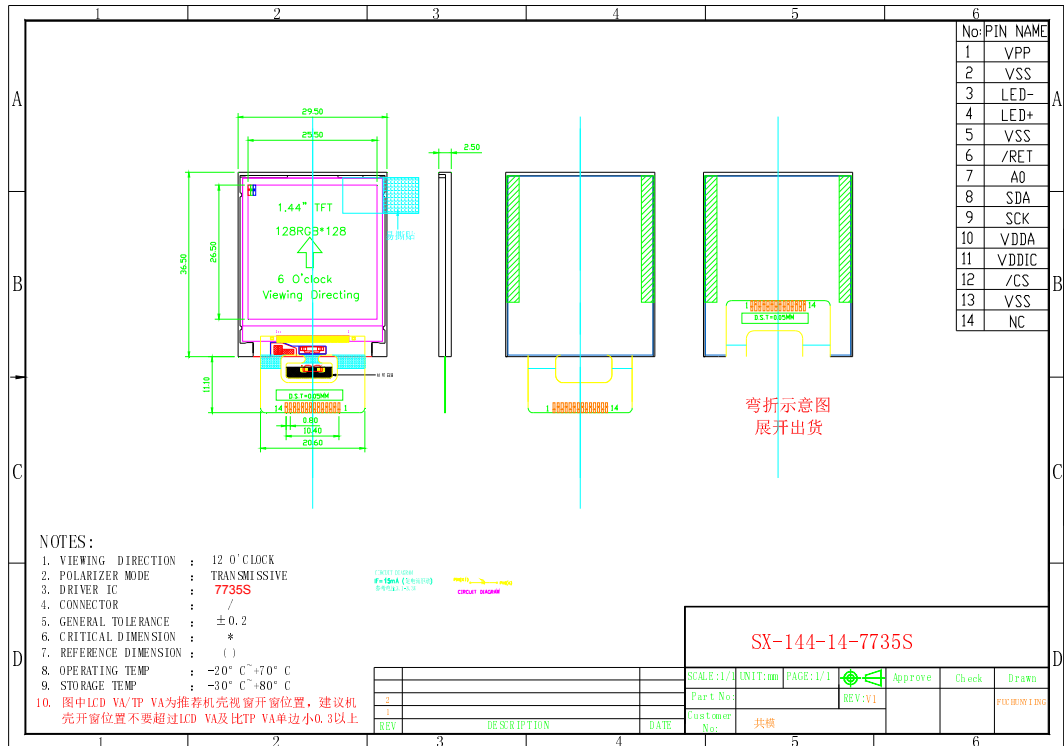

5. 接口定义:

编号	接口定义	引脚功能说明	I/O
1	NC	NC	NC
2	VSS	地	地
3	LED-	背光负极	输入/输出
4	LED+	背光正极	输入/输出
5	VSS	地	地
6	RET	复位	复位
7	A0		
8	SDA		
9	SCK		
10	VDD		
11	VDD		
12	CS		
13	VSS		
14	NC		

6.功能框图:

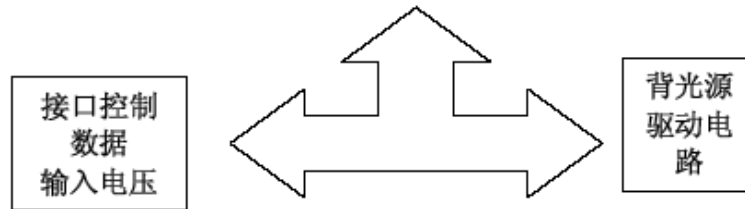

7.接口时序

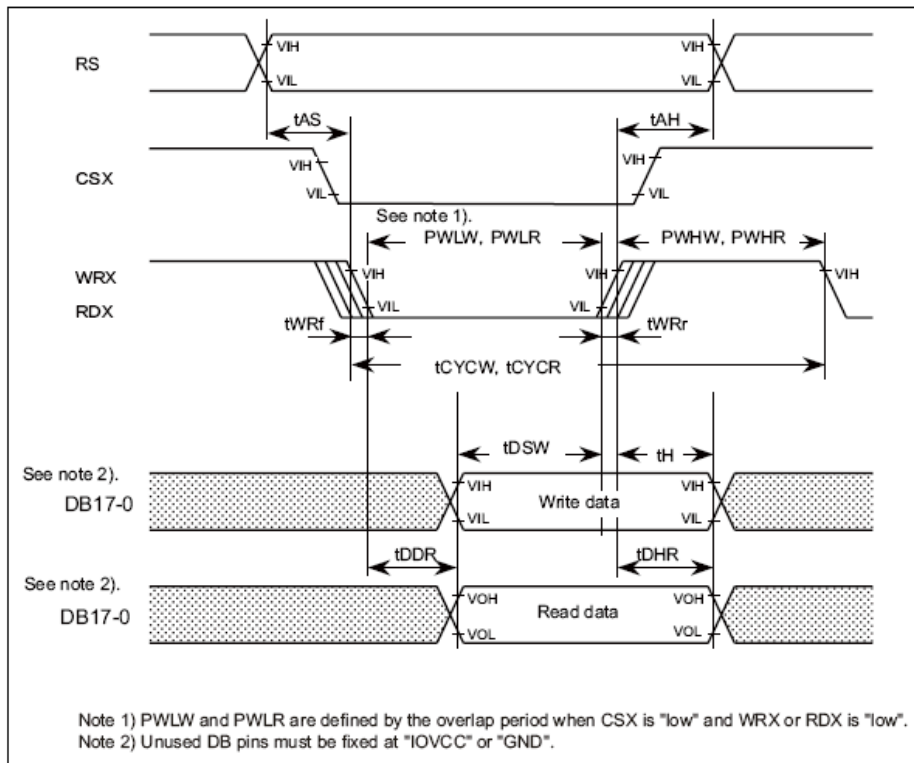

8. 复位时序

Figure C-1 Reset timing when power supply is input

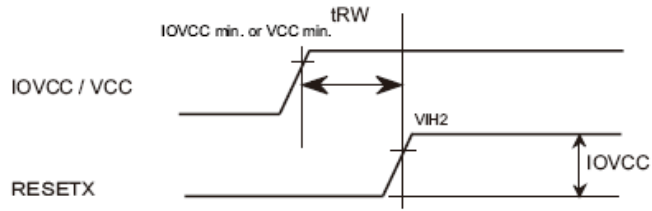
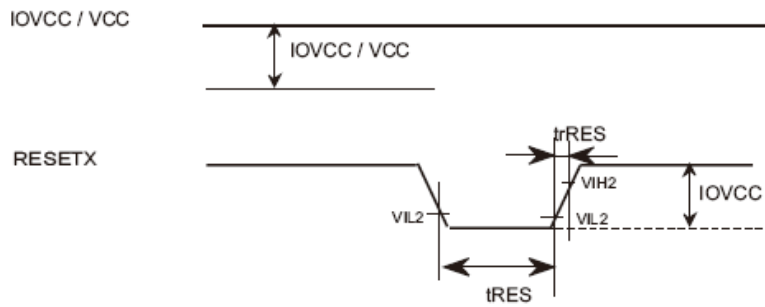

Figure C-2 Reset timing during normal operation



**Table 16 GRAM address and display position on the panel (SS = 0, BGR = 0)**

S/G pin		0	1	2	3	4	5	6	7	8	9	S10	S11	S12	.....	S709	S710	S711	S712	S713	S714	S715	S716	S717	S718	S719	S720
GS=0	GS=1	WD[17:0]			WD[17:0]			WD[17:0]			WD[17:0]			.....	WD[17:0]			WD[17:0]			WD[17:0]			WD[17:0]			
G1	G320	h00000	h00001	h00002	h00003	.....	h000EC	h000ED	h000EE	h000EF																	
G2	G319	h00100	h00101	h00102	h00103	.....	h001EC	h001ED	h001EE	h001EF																	
G3	G318	h00200	h00201	h00202	h00203	.....	h002EC	h002ED	h002EE	h002EF																	
G4	G317	h00300	h00301	h00302	h00303	.....	h003EC	h003ED	h003EE	h003EF																	
G5	G316	h00400	h00401	h00402	h00403	.....	h004EC	h004ED	h004EE	h004EF																	
G6	G315	h00500	h00501	h00502	h00503	.....	h005EC	h005ED	h005EE	h005EF																	
G7	G314	h00600	h00601	h00602	h00603	.....	h006EC	h006ED	h006EE	h006EF																	
G8	G313	h00700	h00701	h00702	h00703	.....	h007EC	h007ED	h007EE	h007EF																	
G9	G312	h00800	h00801	h00802	h00803	.....	h008EC	h008ED	h008EE	h008EF																	
G10	G311	h00900	h00901	h00902	h00903	.....	h009EC	h009ED	h009EE	h009EF																	
G11	G310	h00A00	h00A01	h00A02	h00A03	.....	h00AEC	h00AED	h00AEE	h00AEF																	
G12	G309	h00B00	h00B01	h00B02	h00B03	.....	h00BEC	h00BED	h00BEE	h00BEF																	
G13	G308	h00C00	h00C01	h00C02	h00C03	.....	h00CEC	h00CED	h00CEE	h00CEF																	
G14	G307	h00D00	h00D01	h00D02	h00D03	.....	h00DEC	h00DED	h00DEE	h00DEF																	
G15	G306	h00E00	h00E01	h00E02	h00E03	.....	h00EEC	h00EED	h00EEE	h00EEF																	
G16	G305	h00F00	h00F01	h00F02	h00F03	.....	h00FEC	h00FED	h00FEE	h00FEF																	
G17	G304	h01000	h01001	h01002	h01003	.....	h010EC	h010ED	h010EE	h010EF																	
G18	G303	h01100	h01101	h01102	h01103	.....	h011EC	h011ED	h011EE	h011EF																	
G19	G302	h01200	h01201	h01202	h01203	.....	h012EC	h012ED	h012EE	h012EF																	
G20	G301	h01300	h01301	h01302	h01303	.....	h013EC	h013ED	h013EE	h013EF																	
:	:	:	:	:	:	:	:	:	:	:																	
G305	G16	h13000	h13001	h13002	h13003	.....	h130EC	h130ED	h130EE	h130EF																	
G306	G15	h13100	h13101	h13102	h13103	.....	h131EC	h131ED	h131EE	h131EF																	
G307	G14	h13200	h13201	h13202	h13203	.....	h132EC	h132ED	h132EE	h132EF																	
G308	G13	h13300	h13301	h13302	h13303	.....	h133EC	h133ED	h133EE	h133EF																	
G309	G12	h13400	h13401	h13402	h13403	.....	h134EC	h134ED	h134EE	h134EF																	
G310	G11	h13500	h13501	h13502	h13503	.....	h135EC	h135ED	h135EE	h135EF																	
G311	G10	h13600	h13601	h13602	h13603	.....	h136EC	h136ED	h136EE	h136EF																	
G312	G9	h13700	h13701	h13702	h13703	.....	h137EC	h137ED	h137EE	h137EF																	
G313	G8	h13800	h13801	h13802	h13803	.....	h138EC	h138ED	h138EE	h138EF																	
G314	G7	h13900	h13901	h13902	h13903	.....	h139EC	h139ED	h139EE	h139EF																	
G315	G6	h13A00	h13A01	h13A02	h13A03	.....	h13AEC	h13AED	h13AEE	h13AEF																	
G316	G5	h13B00	h13B01	h13B02	h13B03	.....	h13BEC	h13BED	h13BEE	h13BEF																	
G317	G4	h13C00	h13C01	h13C02	h13C03	.....	h13CEC	h13CED	h13CEE	h13CEF																	
G318	G3	h13D00	h13D01	h13D02	h13D03	.....	h13DEC	h13DED	h13DEE	h13DEF																	
G319	G2	h13E00	h13E01	h13E02	h13E03	.....	h13EEC	h13EED	h13EEE	h13EEF																	
G320	G1	h13F00	h13F01	h13F02	h13F03	.....	h13FEC	h13FED	h13FEE	h13FEF																	



**Table 17 GRAM address and display position on the panel (SS = 1, BGR = 1)**

S/G pin		S720	S719	S718	S717	S716	S715	S714	S713	S712	S711	S710	S709	.....	S12	S11	S10	S9	S8	S7	S6	S5	S4	S3	S2	S1
GS=0	GS=1	WD[17:0]	WD[17:0]	WD[17:0]	WD[17:0]	WD[17:0]	WD[17:0]	WD[17:0]	WD[17:0]	WD[17:0]	WD[17:0]	WD[17:0]	WD[17:0]	.....	WD[17:0]	WD[17:0]	WD[17:0]	WD[17:0]	WD[17:0]	WD[17:0]	WD[17:0]	WD[17:0]	WD[17:0]	WD[17:0]	WD[17:0]	WD[17:0]
G1	G320	h00000	h00001	h00002	h00003	.....	h000EC	h000ED	h000EE	h000EF																
G2	G319	h00100	h00101	h00102	h00103	.....	h001EC	h001ED	h001EE	h001EF																
G3	G318	h00200	h00201	h00202	h00203	.....	h002EC	h002ED	h002EE	h002EF																
G4	G317	h00300	h00301	h00302	h00303	.....	h003EC	h003ED	h003EE	h003EF																
G5	G316	h00400	h00401	h00402	h00403	.....	h004EC	h004ED	h004EE	h004EF																
G6	G315	h00500	h00501	h00502	h00503	.....	h005EC	h005ED	h005EE	h005EF																
G7	G314	h00600	h00601	h00602	h00603	.....	h006EC	h006ED	h006EE	h006EF																
G8	G313	h00700	h00701	h00702	h00703	.....	h007EC	h007ED	h007EE	h007EF																
G9	G312	h00800	h00801	h00802	h00803	.....	h008EC	h008ED	h008EE	h008EF																
G10	G311	h00900	h00901	h00902	h00903	.....	h009EC	h009ED	h009EE	h009EF																
G11	G310	h00A00	h00A01	h00A02	h00A03	.....	h00AEC	h00AED	h00AEE	h00AEF																
G12	G309	h00B00	h00B01	h00B02	h00B03	.....	h00BEC	h00BED	h00BEE	h00BEF																
G13	G308	h00C00	h00C01	h00C02	h00C03	.....	h00CEC	h00CED	h00CEE	h00CEF																
G14	G307	h00D00	h00D01	h00D02	h00D03	.....	h00DEC	h00DED	h00DEE	h00DEF																
G15	G306	h00E00	h00E01	h00E02	h00E03	.....	h00EEC	h00EED	h00EEE	h00EEF																
G16	G305	h00F00	h00F01	h00F02	h00F03	.....	h00FEC	h00FED	h00FEE	h00FEF																
G17	G304	h01000	h01001	h01002	h01003	.....	h010EC	h010ED	h010EE	h010EF																
G18	G303	h01100	h01101	h01102	h01103	.....	h011EC	h011ED	h011EE	h011EF																
G19	G302	h01200	h01201	h01202	h01203	.....	h012EC	h012ED	h012EE	h012EF																
G20	G301	h01300	h01301	h01302	h01303	.....	h013EC	h013ED	h013EE	h013EF																
:	:	:	:	:	:	:	:	:	:	:	:	:	:	:	:	:	:	:	:	:	:	:	:	:	:	:
G305	G16	h13000	h13001	h13002	h13003	.....	h130EC	h130ED	h130EE	h130EF																
G306	G15	h13100	h13101	h13102	h13103	.....	h131EC	h131ED	h131EE	h131EF																
G307	G14	h13200	h13201	h13202	h13203	.....	h132EC	h132ED	h132EE	h132EF																
G308	G13	h13300	h13301	h13302	h13303	.....	h133EC	h133ED	h133EE	h133EF																
G309	G12	h13400	h13401	h13402	h13403	.....	h134EC	h134ED	h134EE	h134EF																
G310	G11	h13500	h13501	h13502	h13503	.....	h135EC	h135ED	h135EE	h135EF																
G311	G10	h13600	h13601	h13602	h13603	.....	h136EC	h136ED	h136EE	h136EF																
G312	G9	h13700	h13701	h13702	h13703	.....	h137EC	h137ED	h137EE	h137EF																
G313	G8	h13800	h13801	h13802	h13803	.....	h138EC	h138ED	h138EE	h138EF																
G314	G7	h13900	h13901	h13902	h13903	.....	h139EC	h139ED	h139EE	h139EF																
G315	G6	h13A00	h13A01	h13A02	h13A03	.....	h13AEC	h13AED	h13AEE	h13AEF																
G316	G5	h13B00	h13B01	h13B02	h13B03	.....	h13BEC	h13BED	h13BEE	h13BEF																
G317	G4	h13C00	h13C01	h13C02	h13C03	.....	h13CEC	h13CED	h13CEE	h13CEF																
G318	G3	h13D00	h13D01	h13D02	h13D03	.....	h13DEC	h13DED	h13DEE	h13DEF																
G319	G2	h13E00	h13E01	h13E02	h13E03	.....	h13EEC	h13EED	h13EEE	h13EEF																
G320	G1	h13F00	h13F01	h13F02	h13F03	.....	h13FEC	h13FED	h13FEE	h13FEF																

### 10. 极限技术参数

Item	Symbol	Unit	Value	Note
Power Supply Voltage 1	VCC, IOVCC	V	-0.3 ~ +4.6	1, 2
Power Supply Voltage 2	VCI – AGND	V	-0.3 ~ +4.6	1, 3
Power Supply Voltage 3	DDVDH – AGND	V	-0.3 ~ +6.5	1, 4
Power Supply Voltage 4	AGND – VCL	V	-0.3 ~ +4.6	1
Power Supply Voltage 5	DDVDH – VCL	V	-0.3 ~ +9.0	1, 5
Power Supply Voltage 7	AGND – VGL	V	-0.3 ~ +13.0	1, 6
Power Supply Voltage 8	VGH– VGL	V	-0.3 ~ +30.0	1
Power Supply Voltage 9	VPP1	V	-0.3 ~ +10.0	1
Power Supply Voltage 10	VPP2	V	-0.3 ~ +10.0	1
Power Supply Voltage 11	VPP3A	V	-10.0 ~ +0.3	1
Input Voltage	Vt	V	-0.3 ~ IOVCC + 0.3	1
Operating Temperature	Topr	°C	-40 ~ +85	1, 7
NVM Write Temperature	Twep	°C	+20 ~ +30	1
NVM Erase Temperature	Teep	°C	+20 ~ +30	1
Storage Temperature	Tstg	°C	-55 ~ +110	1

### 11. 电气参数

Parameter	Symbol	Value			Unit	Notes
		Min.	Typ.	Max.		
TFT Gate ON Voltage	VGH *1)	13	15	17	V	*3)
TFT Gate OFF Voltage	VGL *2)	-11.7	-9.7	-7.7	V	
TFT Common Electrode Voltage	VcomH	-	4.25	-	V	
	VcomL	-	-0.7	-	V	
TFT Kick-Back Voltage Max.	$\Delta V_p$ Max	0.6	-	1.8	V	
TFT Kick-Back Voltage Min.	$\Delta V_p$ Min					

Notes:

\*1) VGH is TFT Gate Operating Voltage.

\*2) VGL is TFT Gate Operating Voltage

The low voltage level of VGL signal must be fluctuated with same phase as Vcom, in case of Cadd (Storage on Gate) structure.

The storage capacitance structure of LH240Q36-SH01 is Cst (Storage on Common)

\*3) Vcom must be adjusted to optimize display quality: Cross-talk, Contrast Ratio and etc.

标准文本	产品规格书	型号	SX-144V03	页数	10
------	-------	----	-----------	----	----

## 12. 背光参数

### 12-1 背光供电方式

### 12-2 LED 白背光特性指标

项目		符号	条件	最小值	典型值	最大值	单位
正向电压		Vf	IF=15mA	2.8	3.2	3.3	V
反向电压		Vr		-	-	-	
正向 电流	Normal	Ipn	2-chip/1chip	10	15	-	mA
	Dimming	Ipd	parallel	1	3	5	
反向电流		Ir	Vr=5V	-	-	-	uA
均匀性			IF=15mA	-	-	-	%
亮度 (覆屏)	主屏		IF=15mA	-		-	cd/m <sup>2</sup>
背光颜色				白色			

## 13. 光电参数

Parameter	Symbol	Values			Unit	Notes
		Min	Typ	Max		
*1) Threshold Voltage	Vsat	4.2	4.3	4.4	V	Fig.2
	Vth	2.0	2.1	2.2	V	
*1) Transmittance	T(%)	-	4.7	-	%	Fig.1
*1) Contrast Ratio	C/R	-	500	-		
*1) Response Time	Tr+Tf	-	35	50	msec	Fig.3, Fig.5
*2) CIE Color Coordinate	Rx	0.637	0.657	0.677		
	Ry	0.300	0.320	0.340		
	Gx	0.267	0.287	0.307		
	Gy	0.571	0.591	0.611		
	Bx	0.120	0.140	0.160		
	By	0.060	0.080	0.100		
	Wx	0.290	0.310	0.330		
Wy	0.307	0.327	0.347			
*1) Viewing Angle	eI	-	80	-	Degree	C/R>10 Fig.4
	eR	-	80	-		
	eU	-	80	-		
	eD	-	80	-		

标准文本	产品规格书	型号	SX-144V03	页数	11
------	-------	----	-----------	----	----

Notes : 1. Contrast Ratio(CR) is defined mathematically as :

$$\text{Contrast Ratio} = \frac{\text{Surface Luminance with all white pixels}}{\text{Surface Luminance with all black pixels}}$$

2. Surface luminance is the center point across the TFT-LCD surface 500 mm from the surface with all pixels displaying white. For more information see FIG 1.
3. Response time is the time required for the display to transition from white to black(Rise Time, Tr) and from black to white(Falling Time, Tf). For additional information see FIG 3.
4. Viewing angle is the angle at which the contrast ratio is greater than 10. The angles are determined for the horizontal or x axis and the vertical or y axis with respect to the z axis which is normal to the TFT-LCD surface. For more information see FIG 4.
5. Optimum contrast is obtained by adjusting the TFT-LCD Threshold voltage(Vth & Vsat)

**FIG. 1 Optical Characteristic Measurement Equipment and Method**

**Pritchard 880 System**

[Test Equipment Set Up]

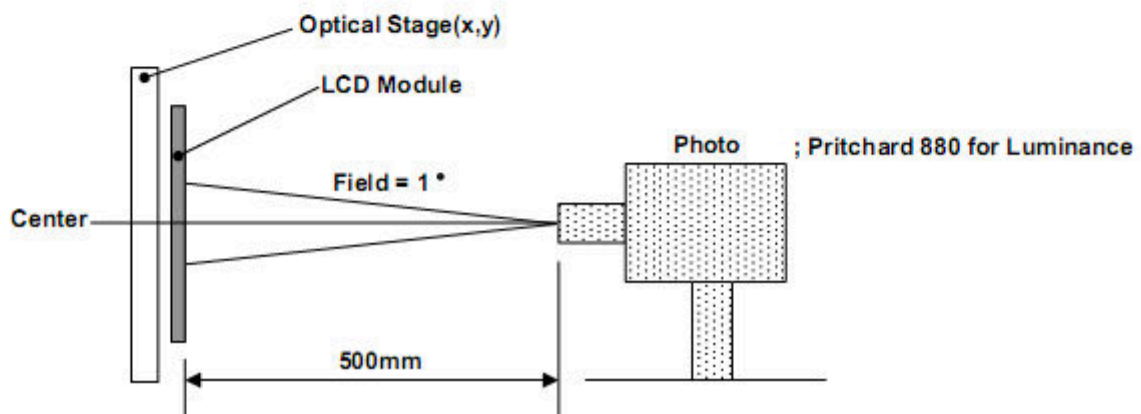

- Measuring Condition ;
  - Measuring surroundings : Dark Room
  - Measuring temperature :  $T_s=25^\circ\text{C}$
  - Adjust operating voltage to get optimum contrast at the center of the display.
  - Measured value at the center point of LCD panel after more than 30 minutes while backlight turning on.

**FIG. 2 The definition of  $V_{th}$  and  $V_{sat}$**

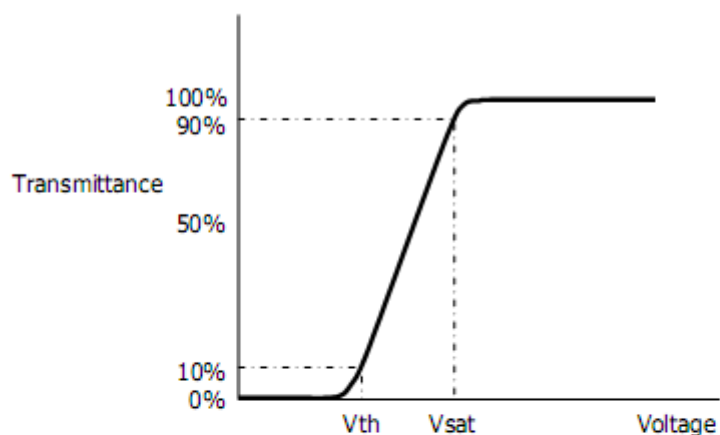

**FIG. 3 The definition of Response Time**

The response time is defined as the following figure and shall be measured by switching the input signal for "black" and "white".

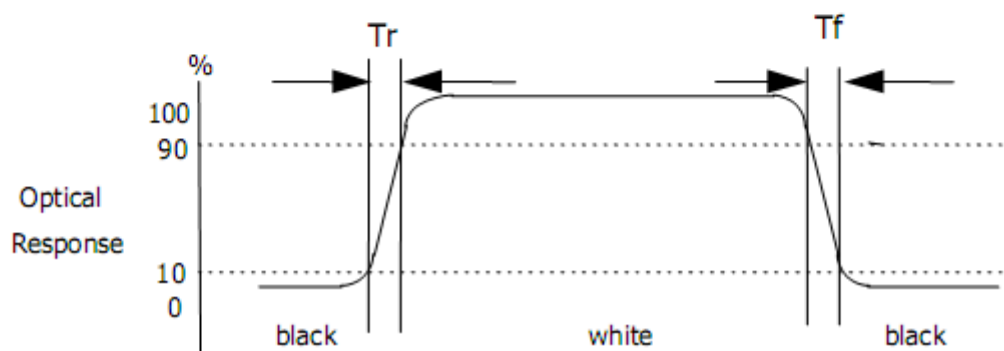

\* Voltage conditions for Response time

$V_{gate}$  : 22V DC

$V_{data}$  : 0V~4.5V DC

$V_{com}$  : 0V (Ground)

**FIG. 4 The definition of viewing angle**

<dimension of viewing angle range>

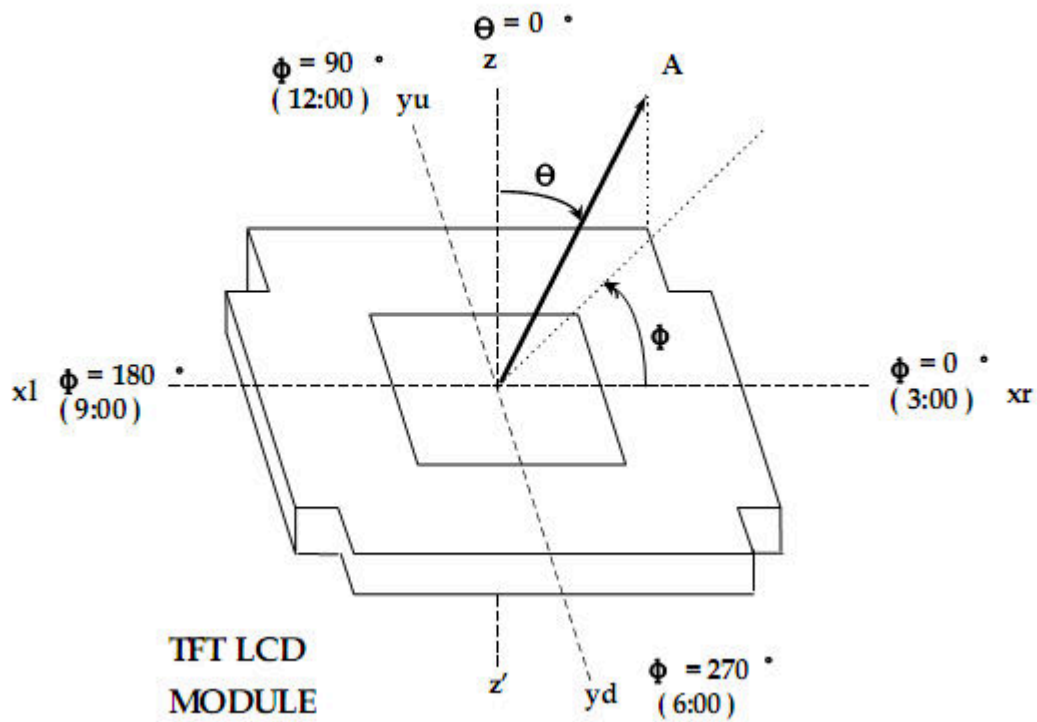

**FIG. 5 Response Time Measurement Equipment and Method**

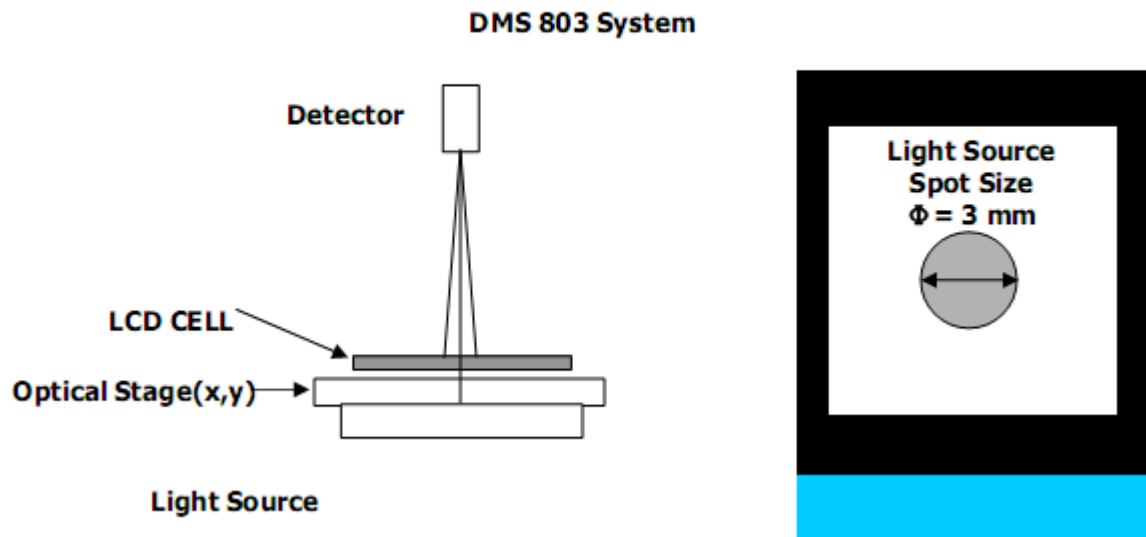

标准文本	产品规格书	型号	SX-144V03	页数	14
------	-------	----	-----------	----	----

#### 14 极限环境参数

ITEM	SYMBOL	CONDITIONS	CRITERION
OPERATING TEMPERATURE	TOPR	-20°C~+70°C	NO DEFECT IN DISPLAYING AND OPERATIONAL FUNCTION
STORAGE TEMPERATURE	TSTG	-30°C~+80°C	NO DEFECT IN DISPLAYING AND OPERATIONAL FUNCTION
HUMIDITY	—	See Note	WITHOUT CONDENSATION

\*NOTE: TEST CONDITION

(1) TEMPERATURE AND HUMIDITY: IF NO SPECIFICATION, TEMP. SET AT 25±2°C, HUMIDITY SET AT 60±5%RH

(2) OPERATING STATE: SAMPLES SUBJECT TO THE TESTS SHALL BE IN "OPERATING" CONDITION

#### 15 可靠性测试

标准文本	产品规格书	型号	SX-144V03	页数	15
------	-------	----	-----------	----	----

Absolute Maximum Conditions

No.	Parameter	Condition
1	Operating Temperature	-20 ~ 70 °C
2	Storage Temperature	-30 ~ 80 °C

Reliability test conditions ( Polarizer characteristics null )

No.	Test Items	Test Condition	
1	High Temperature Storage	T = 80 °C 240hr	Module (Without Contamination)
2	Low Temperature Storage	T = -30 °C for 240hr	
3	High Temperature Operating	T = 70 °C for 240hr	
4	Low Temperature Operating	T = -20 °C for 240hr (But no condensation of dew)	
5	High Temp. and High Humidity Operating	T = 60 °C /90% for 240hr (But no condensation dew)	
6	Thermal Shock	-30 ~ 80 °C, 100cycle	
7	Packing Shock	1 corner, 3 edge, 6 face / 76cm Drop	Packing
8	Packing Vibration	Random Truck 0.57Grms Z direction 1hr.	

※ 1) No.1~ No.6 : No guarantee for panel, only for module with the above test conditions.

2) No.7~ No.8 : Refer to 7-1) Packing Ass'y on page 14.

16. LCM 检验标准

(1) 外观检验项目及标准 (非工作状态)

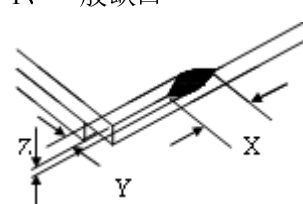
次序	项目	判断标准	AQL												
1	尺寸状况	尺寸超出产品规格	1												
2	缺口	<p>1、一般缺口</p>  <table border="1" style="margin-left: 20px;"> <tr> <td>X</td> <td>Y</td> <td>Z</td> </tr> <tr> <td>≥ K/8</td> <td>不进入 A 区</td> <td>≤ T</td> </tr> </table> <p>2、角缺</p> <table border="1" style="margin-left: 20px;"> <tr> <td>X</td> <td>Y</td> <td>Z</td> </tr> <tr> <td>≥ K/8</td> <td>不进入 A 区</td> <td>不计</td> </tr> </table>	X	Y	Z	≥ K/8	不进入 A 区	≤ T	X	Y	Z	≥ K/8	不进入 A 区	不计	2.50
X	Y	Z													
≥ K/8	不进入 A 区	≤ T													
X	Y	Z													
≥ K/8	不进入 A 区	不计													



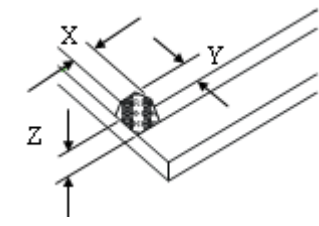

3、引脚部位缺口

X	Y	Z
$\geq K/8$	$\geq L/3$	不计

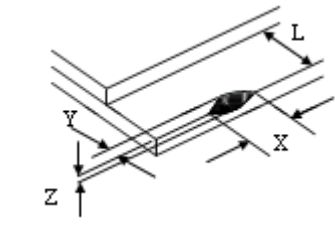

4、边缘突起

X	Y
$\geq K/8$	$\geq L/3$

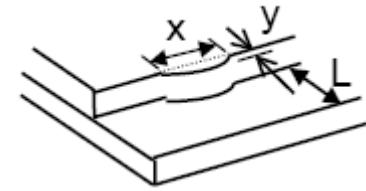

缺口伤及线路斑马纸产品  $Y \leq L/5$ ；导电胶条产品  $Y \leq L/3$ ；装脚产品  $Y \leq 0.3\text{mm}$  判断

3 点状缺陷

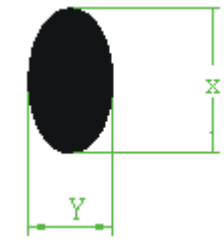

D	允许缺陷数	
	A/B 区	C 区
$D < 0.2$	不限	
$0.2 \leq D < 0.3$	2	
$0.3 \leq D \leq 0.5$	1	
$D > 0.5$	0	

X:长径  
Y:短径  
D:平均直径  $D = (X+Y)/2$

2.50

4 线状缺陷

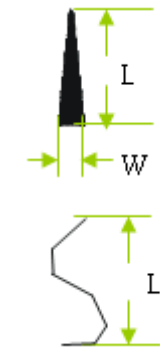

长度	宽度	允许缺陷数	
		A/B 区	C 区
不计	$W \leq 0.02$	不计	不限
$L \leq 3$	$W \leq 0.05$	2	
$L \leq 2.5$	$W \leq 0.05$	2	按点状缺陷判定
	$W > 0.05$		

L:长度 W:宽度

2.50

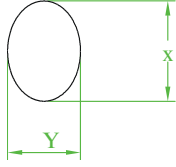
标准文本	产品规格书	型号	SX-144V03	页数	17													
		对偏光片（刮伤、污点、压痕）有限度样本则以限度样本判断																
5	偏光片 气泡/水纹/皱纹		<table border="1"> <thead> <tr> <th rowspan="2">D</th> <th colspan="2">允许缺陷数</th> </tr> <tr> <th>A/B 区</th> <th>C 区</th> </tr> </thead> <tbody> <tr> <td><math>D \leq 0.2</math></td> <td>不限</td> <td rowspan="4">不限</td> </tr> <tr> <td><math>0.2 \leq D \leq 0.5</math></td> <td>3 个</td> </tr> <tr> <td><math>0.5 \leq D \leq 1.0</math></td> <td>2 个</td> </tr> <tr> <td><math>D &gt; 1.0</math></td> <td>0 个</td> </tr> </tbody> </table>	D	允许缺陷数		A/B 区	C 区	$D \leq 0.2$	不限	不限	$0.2 \leq D \leq 0.5$	3 个	$0.5 \leq D \leq 1.0$	2 个	$D > 1.0$	0 个	2.50
D	允许缺陷数																	
	A/B 区	C 区																
$D \leq 0.2$	不限	不限																
$0.2 \leq D \leq 0.5$	3 个																	
$0.5 \leq D \leq 1.0$	2 个																	
$D > 1.0$	0 个																	
6	外丝印	1、丝印变形、针孔：按照字符变形针孔规格判断。 2、丝印宽度：丝印宽度 $\geq 1/2$ 标准宽度，可判 OK。			2.50													
7	打胶（硅胶）	打胶面积必须盖住 ITO 引线			2.50													
8	PCB 板不良	1、PCB 板烧焦、版本不符、线路剥离、裂痕、导电过孔堵不允许 2、PCB 板金手指不可有氧化、腐蚀、胶状物、断裂现象			2.50													
9	贴片元件	1、元件装配上下、左右偏位 $\leq 1/3$ 元件本体宽度 2、焊锡点尽可能光滑圆润 3、元件受损、破裂、少件、多件、元件装配反向、漏焊不允许			2.50													
10	铁框	破裂、变形不允许 外形尺寸参照产品规格书			2.50													

(2) 显示功能检验项目及标准（工作状态）

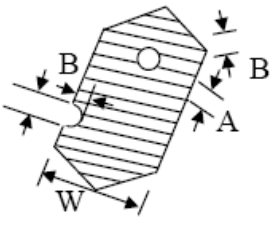
1	电性能缺陷	断路	不允许	1.0						
		短路/大电流	不允许							
		视角错误	不允许							
2	字划 凸起/缺口	1、针孔缺口 	<table border="1"> <thead> <tr> <th>宽度</th> <th>接收规格</th> </tr> </thead> <tbody> <tr> <td><math>W &lt; 0.4</math></td> <td><math>D \leq 0.2</math> &amp; <math>D \leq 1/2W</math></td> </tr> <tr> <td><math>W \geq 0.4</math></td> <td><math>D \leq 0.25</math> &amp; <math>D \leq 1/3W</math></td> </tr> </tbody> </table> <p>* <math>D = (A+B) / 2</math>    <math>D \leq 0.1</math> 则忽略不计</p>	宽度	接收规格	$W < 0.4$	$D \leq 0.2$ & $D \leq 1/2W$	$W \geq 0.4$	$D \leq 0.25$ & $D \leq 1/3W$	2.50
宽度	接收规格									
$W < 0.4$	$D \leq 0.2$ & $D \leq 1/2W$									
$W \geq 0.4$	$D \leq 0.25$ & $D \leq 1/3W$									

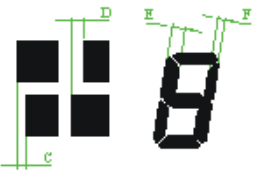
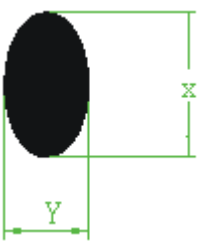
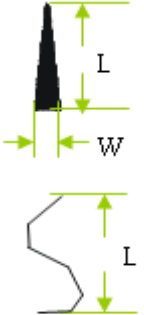
3	字划/图案 粗细	 <table border="1" style="margin-left: auto; margin-right: auto;"> <tr> <th>宽度</th> <th>接收规格</th> </tr> <tr> <td><math>W &lt; 0.4</math></td> <td><math>C、D、G \leq 1/2W</math></td> </tr> <tr> <td><math>W \geq 0.4</math></td> <td><math>C、D、G \leq 0.2</math></td> </tr> </table> <p style="text-align:center;">W: 图案设计尺寸      C、D: 差异尺寸      <math>G =  E - F </math></p>	宽度	接收规格	$W < 0.4$	$C、D、G \leq 1/2W$	$W \geq 0.4$	$C、D、G \leq 0.2$	1.0																
宽度	接收规格																								
$W < 0.4$	$C、D、G \leq 1/2W$																								
$W \geq 0.4$	$C、D、G \leq 0.2$																								
4	点状缺陷	 <table border="1" style="margin-left: auto; margin-right: auto;"> <tr> <th rowspan="2">D</th> <th colspan="2">允许缺陷数</th> </tr> <tr> <th>A/B 区</th> <th>C 区</th> </tr> <tr> <td><math>D &lt; 0.1</math></td> <td colspan="2">不限</td> </tr> <tr> <td><math>0.1 \leq D &lt; 0.2</math></td> <td colspan="2">2</td> </tr> <tr> <td><math>0.2 \leq D \leq 0.25</math></td> <td colspan="2">1</td> </tr> <tr> <td><math>D &gt; 0.25</math></td> <td colspan="2">0</td> </tr> </table> <p>X:长径 Y:短径 D:平均直径 <math>D = (X + Y) / 2</math> 如黑点、污迹在字段区, 按“笔段缺陷”判定</p>	D	允许缺陷数		A/B 区	C 区	$D < 0.1$	不限		$0.1 \leq D < 0.2$	2		$0.2 \leq D \leq 0.25$	1		$D > 0.25$	0		2.50					
D	允许缺陷数																								
	A/B 区	C 区																							
$D < 0.1$	不限																								
$0.1 \leq D < 0.2$	2																								
$0.2 \leq D \leq 0.25$	1																								
$D > 0.25$	0																								
5	线状缺陷	 <table border="1" style="margin-left: auto; margin-right: auto;"> <tr> <th rowspan="2">长度</th> <th rowspan="2">宽度</th> <th colspan="2">允许缺陷数</th> </tr> <tr> <th>A/B 区</th> <th>C 区</th> </tr> <tr> <td>不计</td> <td><math>W \leq 0.02</math></td> <td colspan="2">不计</td> </tr> <tr> <td><math>L \leq 3</math></td> <td><math>W \leq 0.03</math></td> <td colspan="2">2</td> </tr> <tr> <td rowspan="2"><math>L \leq 2.5</math></td> <td><math>0.03 &lt; W \leq 0.05</math></td> <td colspan="2">2</td> </tr> <tr> <td><math>W &gt; 0.05</math></td> <td colspan="2">按点状缺陷判定</td> </tr> </table> <p>L:长度    W:宽度</p>	长度	宽度	允许缺陷数		A/B 区	C 区	不计	$W \leq 0.02$	不计		$L \leq 3$	$W \leq 0.03$	2		$L \leq 2.5$	$0.03 < W \leq 0.05$	2		$W > 0.05$	按点状缺陷判定		2.50	
长度	宽度	允许缺陷数																							
		A/B 区	C 区																						
不计	$W \leq 0.02$	不计																							
$L \leq 3$	$W \leq 0.03$	2																							
$L \leq 2.5$	$0.03 < W \leq 0.05$	2																							
	$W > 0.05$	按点状缺陷判定																							

## 17 LCM 的使用

### 16-1 晶显示模块

LCD 是由玻璃和偏光片组成, 在搬运过程中, 请注意以下事项:

- (1) 请保证使用和存储是在规定的温度范围之内。高温高湿会导致偏光性能降级, 产生气泡或者偏光片剥落。
- (2) LCM 表面的偏光片质软容易划伤, 不要用硬度大于 HB 铅笔芯的任何物品 (玻璃, 镊子等) 接触, 挤压或者摩擦外露的偏光片
- (3) 用来粘合底/面偏光片和反射片的有机粘合剂会被一些化学物质, 如丙酮, 甲苯, 乙醇和异链烷烃破坏, 建议用 N-己烷进行清洁。
- (4) 显示屏表面有脏污, 请吹拂同时用干的软布擦拭表面。如果脏污比较严重, 建议用脱脂棉或者其他的柔软材料, 如擦拭用软皮, 浸湿异丙醇或酒精之后进行擦拭其表面。不要用力擦洗以避免损伤显示屏表面。
- (5) 不可使用以下溶剂: 水, 酮, 芳香烃。其溶剂可能损坏偏光片。

标准文本	产品规格书	型号	SX-144V03	页数	19
------	-------	----	-----------	----	----

- (6) 避免与油和脂肪接触。
- (7) 因低温而产生的表面浓缩和端子的连接，会损坏，染污或者弄脏偏光片。产品在低温测试之后，需要先在容器之内烘干之后才可以与室温接触。
- (8) 不要放置或贴附任何东西在屏幕上，以免留下痕迹。
- (9) 不要裸手触摸显示器。这样会染污显示区域，并且降低接线端子之间的绝缘性（对于偏光片一些化妆品是确定的）
- (10) 采取措施尽量减小电极的腐蚀。水滴，凝结的潮气或者高湿环境下的电流会加速电极的腐蚀。
- (11) 因为玻璃是易碎的，搬运过程中容易产生缺口（特别是边缘）。请避免跌落或震动。

#### 16-2 组装 LCM 的注意事项

因为 LCM 是高精密度的组装和调试，请避免因过度的撞击，或者进行任何的变更或者修改。

- (1) 不要更改或者改变金属框架的突起形状。
- (2) 不要在线路印刷板上另外钻孔，修改形状或者改变其上的元器件的位置。
- (3) 不要损坏或者修改线路印刷板上的图案。
- (4) 绝对不要更改斑马条（导电橡胶）或者热压连接器。
- (5) 除了焊接接口，不要用烙铁进行任何的修改或者变更。
- (6) 不要跌落，弯曲或者扭转 LCM。特别注意不可用力拉或者扭转 I/O 口或背光的排线。
- (7) 为了防止 FPC 破裂，请特别注意 FPC 的可弯曲部分，覆盖层的边缘，镀金区域的表面，焊接区域或者通孔区域。

#### 16-3 静电放电控制

因为模块使用 CMOS LSI,像平常的 CMOS IC 一样需要注意静电的防护。

- (1) 手持 LCM 时，请确保身体是接地的。为了尽量减少因静电而产生的 LCM 功能降级，在运输模块时小心操作避免接触到：印刷电路板的外露区域，元件的电极。
- (2) 从包装袋中取出 LCM 或者与其他装置装配时，请确保模块与你的身体的电势一致。
- (3) 焊接 LCM 的接线端时，请确保烙铁的交流电源没有漏电。
- (4) 使用电动螺丝批装配 LCM 时，电动螺丝批须接地以尽可能减小马达换向器产生火花而引起的电磁波辐射
- (5) 尽量使你的工衣，工作台达到地电位。
- (6) 为了减少静电产生需要注意工作环境的空气不可太干燥。建议相对湿度为 50%-60%。

#### 16-4 操作注意事项：

- (1) 液晶的视角会随着驱动电压（VO）的变化而变化，调节 VO 使之显示为最好的对比度。
- (2) 极限值以上的驱动电压会缩短 LCD 的使用寿命。
- (3) 如果 LCM 长时间的显示一个图案，图案可能残存（似鬼影）或者其暗影不规则的显示。隔段时间后使用即可恢复正常。请注意这种现象不会影响显示。
- (4) 在低于操作温度范围的温度下工作会造成响应时间延长。但是，这并不意味着 LCD 不能工作。它会在温度恢复至规定范围后恢复正常。
- (5) 如果在工作过程中显示区域被猛烈的挤压，显示会异常。但是，关电后重新启动后会恢复正常。
- (6) 端子的凝结水汽会导致电化学反应，破坏线路的接线端。所以，必须在低于 40℃，50% RH 环境条件下中使用。
- (7) 电源打开，在正极/负极电压稳定之后，输入信号。

标准文本	产品规格书	型号	SX-144V03	页数	20
------	-------	----	-----------	----	----

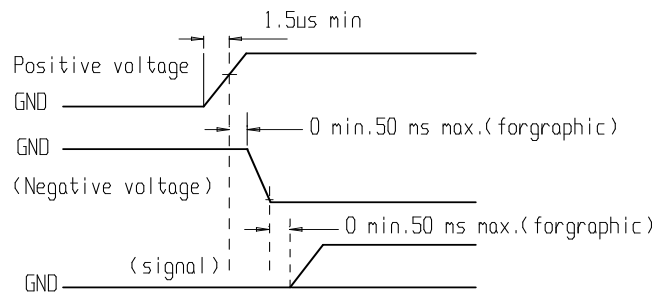

#### 16-5 储存

如果 LCD 需储存几年，以下的预防事项是必要的。

- (1) 保存于密封的聚乙烯袋内。适当的密封就不需要干燥剂。
- (2) 存储于黑暗的环境中。不要暴露于日光或者荧光灯的直射下，保持温度在 0°C 到 35°C 之间。
- (3) 偏光片的表面不可与其他物体接触。（建议存于运输用的容器中）
- (4) 环境条件
  - 不要在 70°C 的环境中放置超过 160 小时。
  - 不要在 -20°C 的环境中放置超过 48 小时。

#### 16-6 安全

- (1) 建议将损坏的或者不要的 LCD 压成碎片，用溶剂，如丙酮，乙醇清洗后烧毁。
- (2) 如果从破损的玻璃中泄漏的液晶不慎粘到手，请用肥皂，清水彻底清洗。

#### 16-7 权利限制

除非经过上线科技公司和客户的认可，在交货之日起一年之内，上线科技公司会按照自己承诺的检验标准对 LCD 功能性的缺陷进行修改。外观上缺陷的产品必须在交货之日起 30 天之内退回上线科技公司。以上日期依运输文件为准。上线科技公司的权力范围仅限于对以上项目的修复和/或者替换。上线科技公司不会对由此引起的或者并发的其他事件负责。

#### 16-8 权利范围之内的退货

如有违反以上所提到的预防注意事项而造成的不良将不予以保证。典型例子如下：

- 破坏 LCD 玻璃。
- 任何形式的线路修改，包括增加电器元件。

模块的修改必须基于客户相互的文件协议。模块退回时，必须要有详细的不良描述。客户安装的连接器或者排线必须完全地取掉，不能损坏 LCM 的 PCB 孔，连接器和接线端。

**规格书技术资料备注：由于液晶产品技术不断改进，本规格书有未能把所有技术资料体现，请客户务必在确定产品时，以样品质量和结构为准，以免造成生产批量出现不必要的损失，谢谢支持和配合！**